

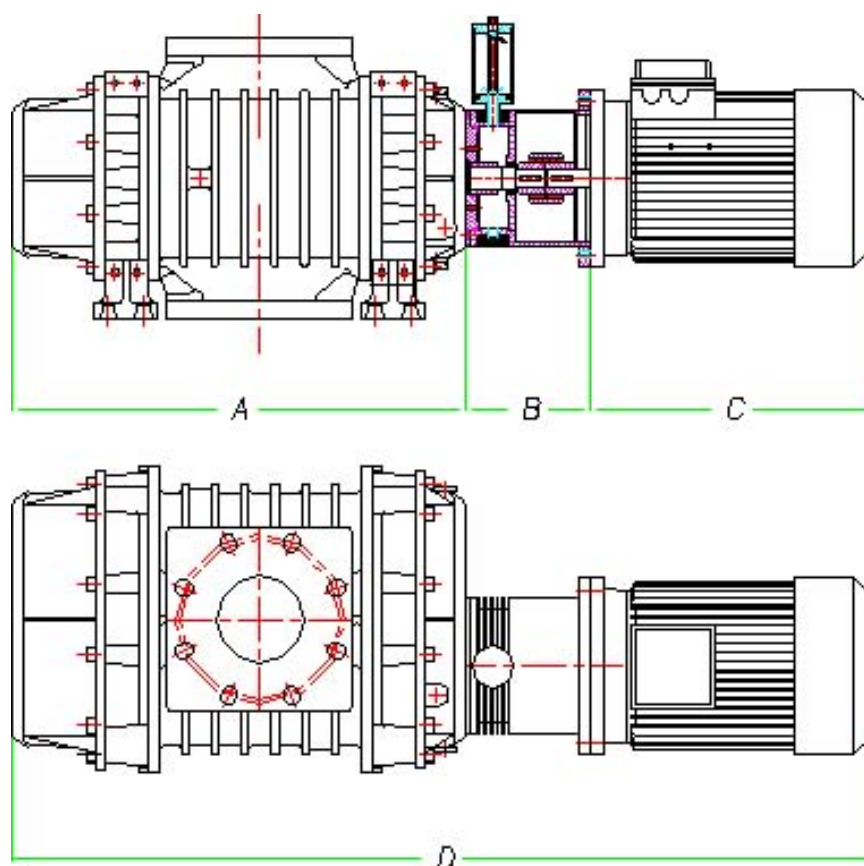

POMPE VOLUMETRICHE PER ALTO VUOTO  
HIGHVACUUM POSITIVE DISPLACEMENT PUMPS



<u>MODELLO</u>	<u>PORTATA NOMINALE A 2850 RPM</u>	<u>POTENZA CONSIGLIATA</u>	A (mm)	B (mm)	C (mm)	D (mm)	KG
<b>163 HV</b>	<b>500 m<sup>3</sup>/h</b>	<b>2.2 KW</b>	<b>419</b>	<b>177</b>	<b>272</b>	<b>868</b>	<b>141</b>
<b>233 HV</b>	<b>700 m<sup>3</sup>/h</b>	<b>3 KW</b>	<b>469</b>	<b>177</b>	<b>301</b>	<b>947</b>	<b>155</b>
<b>293 HV</b>	<b>900 m<sup>3</sup>/h</b>	<b>3 KW</b>	<b>516</b>	<b>177</b>	<b>301</b>	<b>994</b>	<b>167</b>
<b>353 HV</b>	<b>1100 m<sup>3</sup>/h</b>	<b>4 KW</b>	<b>574</b>	<b>177</b>	<b>301</b>	<b>1052</b>	<b>187</b>
<b>463 HV</b>	<b>1450 m<sup>3</sup>/h</b>	<b>4 KW</b>	<b>674</b>	<b>177</b>	<b>301</b>	<b>1152</b>	<b>205</b>
<b>673 HV</b>	<b>2000 m<sup>3</sup>/h</b>	<b>5.5 KW</b>	<b>638</b>	<b>177</b>	<b>301</b>	<b>1116</b>	<b>257</b>
<b>883 HV</b>	<b>2500 m<sup>3</sup>/h</b>	<b>7.5 KW</b>	<b>715</b>	<b>177</b>	<b>390</b>	<b>1282</b>	<b>299</b>